

## DG BluePRO 100/2/G40V A1BM/50

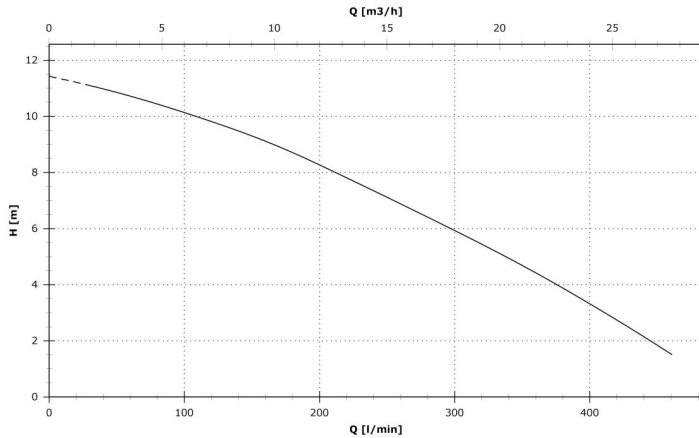

Set-back Vortex impeller  
 Rated power output (P2) 0.74 kW  
 Free passage 40 mm

## Technical data

Number of poles	2
Rated power output (P2)	0.74 kW
Input power (P1)	1.2 kW
Nominal absorbed current (In)	5.6 A
rated power factor (cos phi)	0.97
Nominal power frequency (f)	50 Hz
Rated nominal voltage(Vn)	230 V
N° phases	1
IPMotor	68
ATEX thermal class	not applicable
insulation class	F

## Constructive characteristics

Outlet	G1"½
Outlet orientation	V (vertical)
Type of starting	D
Weight	15.5 kg
Standard cable type	H07RN-F 3G1
EX cable type	N.A.
Standard paint type	Bicomponent epoxy paint
Maximum acoustic pressure	70 dB
Set of standard mechanical seals	Two Silicon carbide mechanical seals (SiC)
Probe for water presence	

## Use limits

Maximum operating temperature	40 °C
Maximum immersion depth	20 m
PH of treated fluid	6 to 14 pH
max starts per hour	30

## Materials

Case	Grey Cast Iron - EN-GJL 250 (02)
Shaft	Stainless Steel - AISI 420 (23)
Cooling jacket	Not applicable (00)
Standard gasket	Rubber - NBR (77)
EX gasket	Not applicable (00)
Nuts and bolts	Stainless Steel - Class A2-70 (42)
Hydraulic	Grey Cast Iron - EN-GJL 250 (02)
Impeller	Grey Cast Iron - EN-GJL 250 (02)
Cutting disk	Not applicable (00)
Cutter	Not applicable (00)
Grid	Not applicable (00)

## Test limits

Density of treated fluid	1 Kg/dm <sup>3</sup>
Viscosity of treated fluid	1 mm <sup>2</sup> /s

## Pump

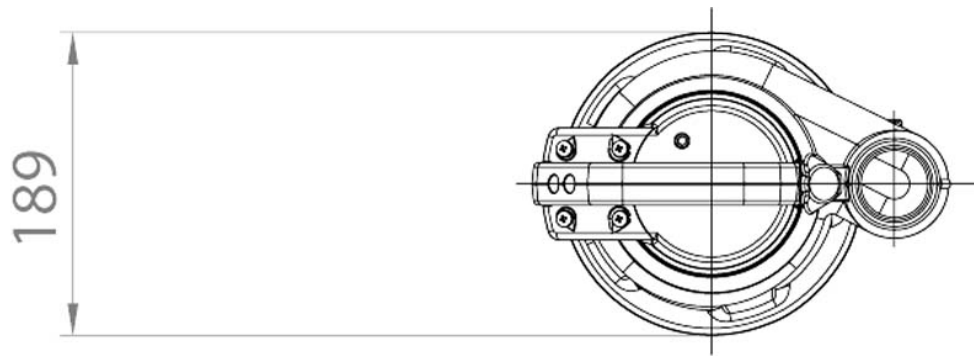
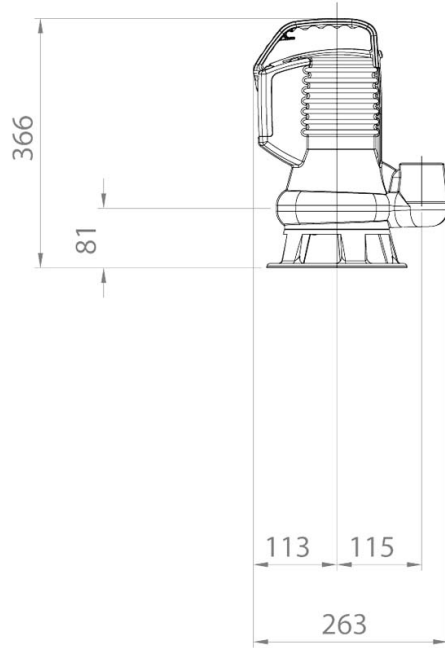

## Bottom coupling devices with vertical outlet

